

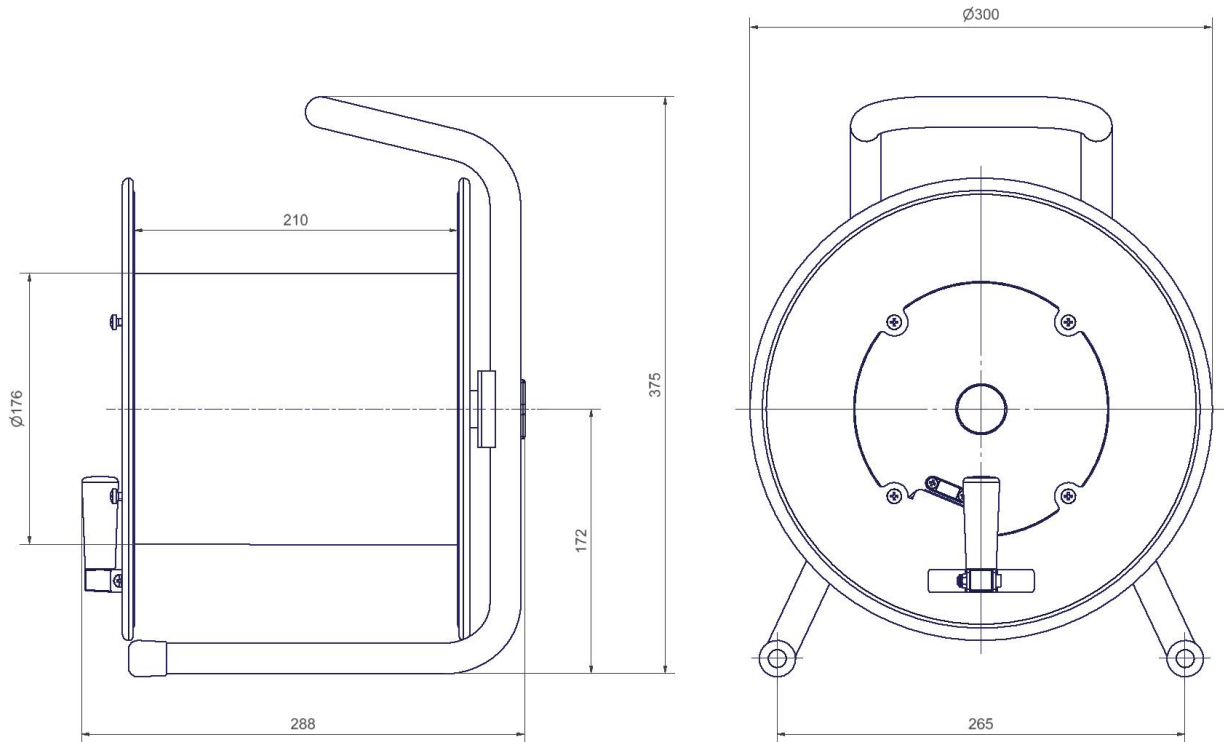

**HT 305.OPEN**

Part-No. 338 00 000 000

<b>Version</b>	Open
<b>Material</b>	Sheet steel
<b>Weight (kg)</b>	3.99



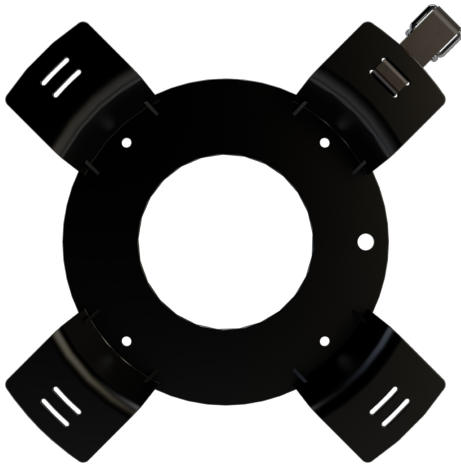

**KOMB RM WITH LEATHER STRAP**

Part-No. 64 010 010

**Version 1**

for HT 380 - HT 582 + GT 310/IT 300K/IT

**Version 2**

-

**Type**

Cover

